



Simulační model vozu Formule Student ČVUT

BAKALÁŘSKÁ PRÁCE

Autor: Jiří Volech
Studijní obor: Teoretický základ strojního inženýrství
Vedoucí práce: Prof. Ing. Šika Zbyněk Ph.D.

Vytvoření a popsání modelů Formule Student ČVUT

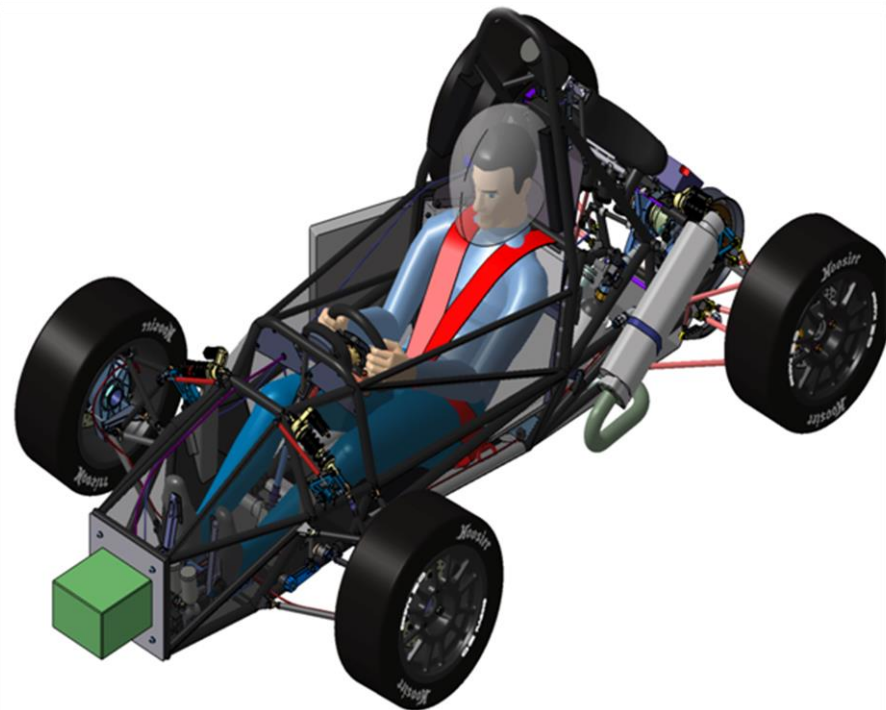

Zdroj: Karniš Tomáš

Poloviční model formule

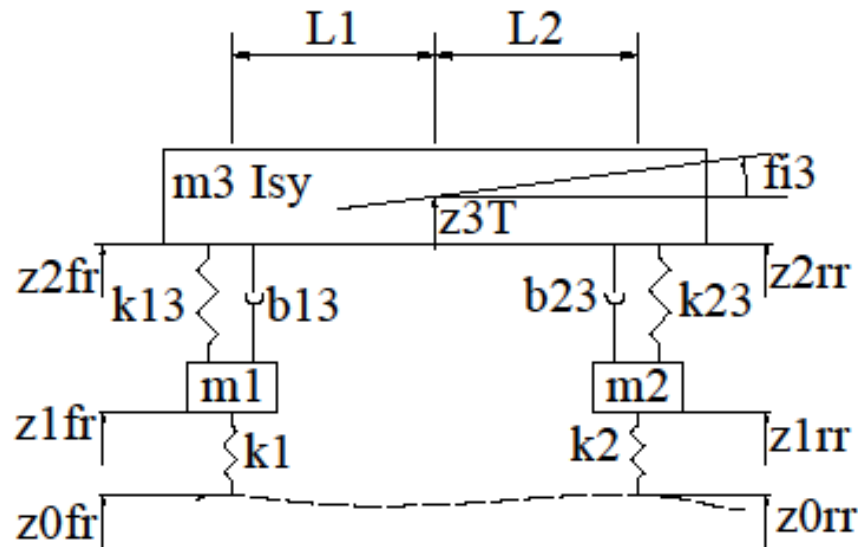

$$m_1 \ddot{z}_{1fr} = k_{13} * (z_{2fr} - z_{1fr}) + b_{13} * (\dot{z}_{2fr} - \dot{z}_{1fr}) - k_1 * (z_{1fr} - z_{0fr})$$

$$m_2 \ddot{z}_{1rr} = k_{23} * (z_{2rr} - z_{1rr}) + b_{23} * (\dot{z}_{2rr} - \dot{z}_{1rr}) - k_2 * (z_{1rr} - z_{0rr})$$

$$m_3 \ddot{z}_{3T} = k_{13} * (z_{2fr} - z_{1fr}) + b_{13} * (\dot{z}_{2fr} - \dot{z}_{1fr}) - k_{23} * (z_{2rr} - z_{1rr}) + b_{23} * (\dot{z}_{2rr} - \dot{z}_{1rr})$$

$$I_{sy} \ddot{\phi}_3 = \begin{bmatrix} k_{13} * (z_{2fr} - z_{1fr}) \\ + b_{13} * (\dot{z}_{2fr} - \dot{z}_{1fr}) \end{bmatrix} * L_1 - \begin{bmatrix} k_{23} * (z_{2rr} - z_{1rr}) \\ + b_{23} * (\dot{z}_{2rr} - \dot{z}_{1rr}) \end{bmatrix} * L_2$$

Celkový model formule

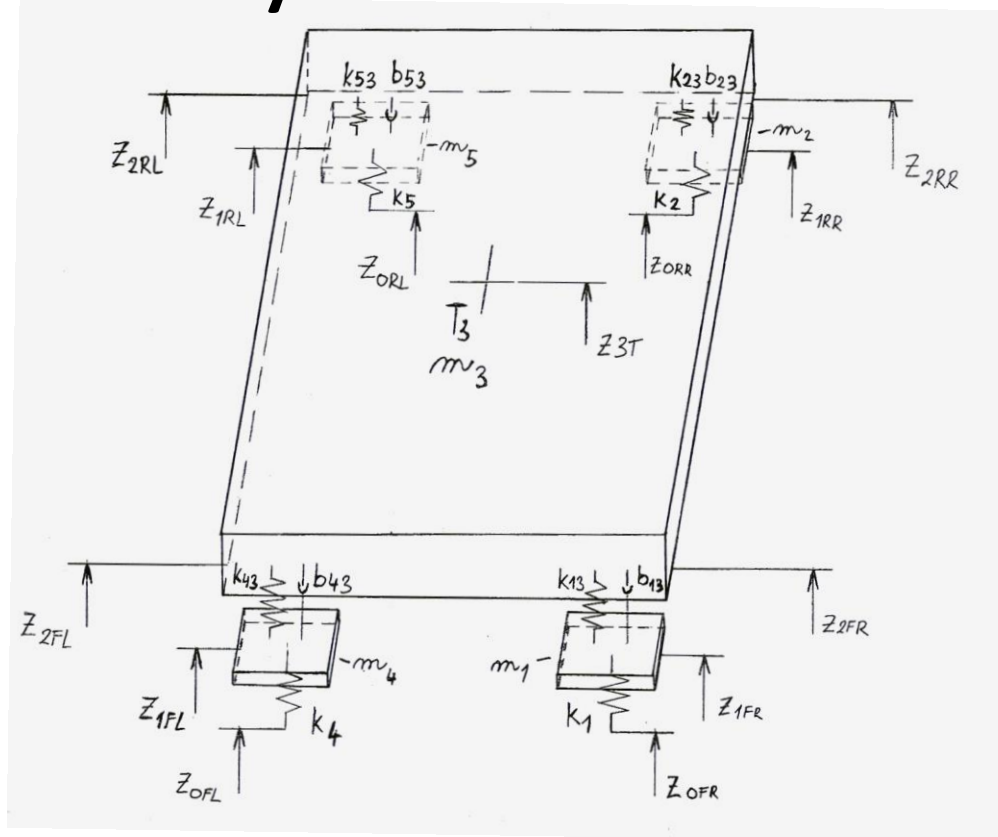

Model v Simulinku

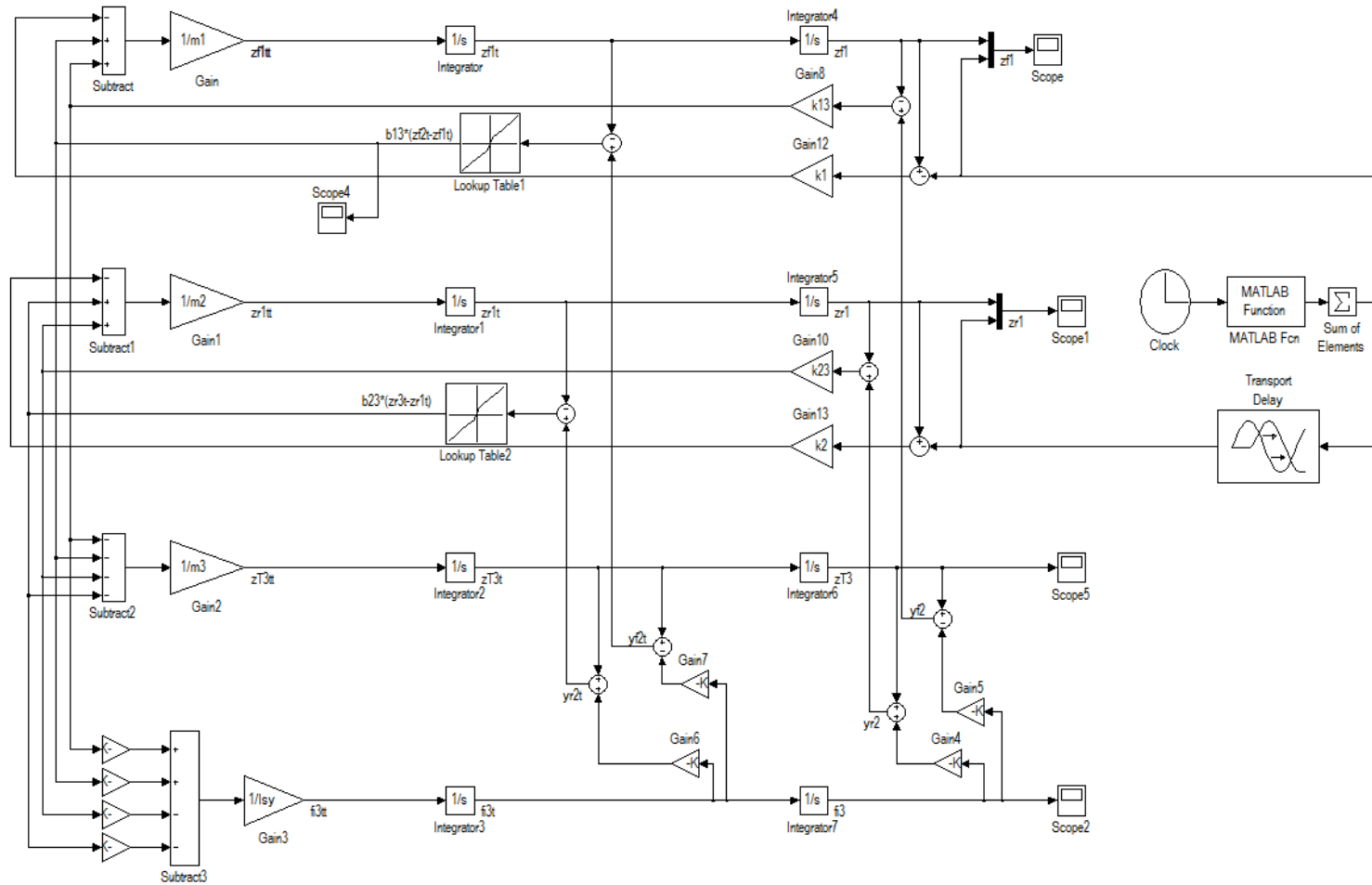

Uvolnění karoserie

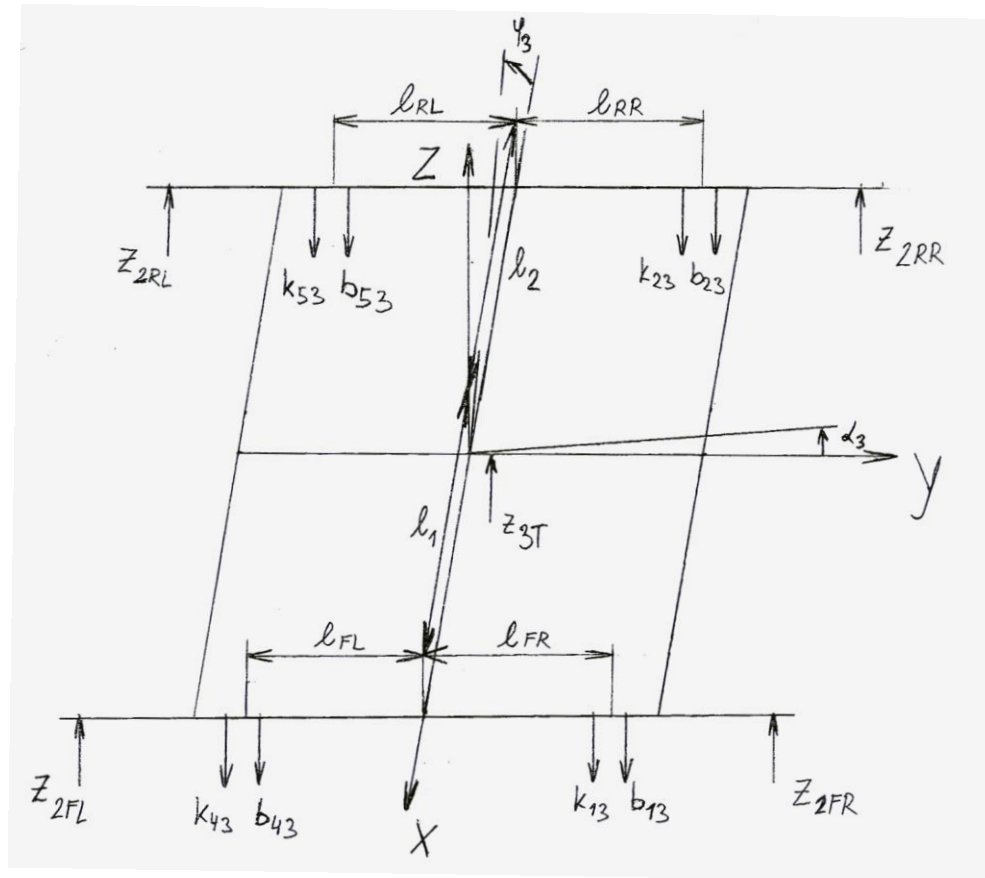

Popis celkového modelu

$$m_1 \ddot{z}_{1fr} = k_{13} * (z_{2fr} - z_{1fr}) + b_{13} * (\dot{z}_{2fr} - \dot{z}_{1fr}) - k_1 * (z_{1fr} - z_{0fr})$$

$$m_2 \ddot{z}_{1rr} = k_{23} * (z_{2rr} - z_{1rr}) + b_{23} * (\dot{z}_{2rr} - \dot{z}_{1rr}) - k_2 * (z_{1rr} - z_{0rr})$$

$$m_3 \ddot{z}_{3T} = -k_{13} * (z_{2fr} - z_{1fr}) - b_{13} * (\dot{z}_{2fr} - \dot{z}_{1fr}) - k_{23} * (z_{2rr} - z_{1rr}) \\ - b_{23} * (\dot{z}_{2rr} - \dot{z}_{1rr}) - k_{43} * (z_{2fl} - z_{1fl}) - b_{43} * (\dot{z}_{2fl} - \dot{z}_{1fl}) - k_{53} \\ * (z_{2rl} - z_{1rl}) - b_{53} * (\dot{z}_{2rl} - \dot{z}_{1rl})$$

$$m_4 \ddot{z}_{1fl} = k_{43} * (z_{2fl} - z_{1fl}) + b_{43} * (\dot{z}_{2fl} - \dot{z}_{1fl}) - k_4 * (z_{1fl} - z_{0fl})$$

$$m_5 \ddot{z}_{1rl} = k_{53} * (z_{2rl} - z_{1rl}) + b_{53} * (\dot{z}_{2rl} - \dot{z}_{1rl}) - k_5 * (z_{1rl} - z_{0rl})$$

$$I_{sx} \ddot{\alpha}_3 = -[k_{13} * (z_{2fr} - z_{1fr}) + b_{13} * (\dot{z}_{2fr} - \dot{z}_{1fr})] * L_{fr} \\ - [k_{23} * (z_{2rr} - z_{1rr}) + b_{23} * (\dot{z}_{2rr} - \dot{z}_{1rr})] * L_{rr} \\ + [k_{43} * (z_{2fl} - z_{1fl}) + b_{43} * (\dot{z}_{2fl} - \dot{z}_{1fl})] * L_{fl} \\ + [k_{53} * (z_{2rl} - z_{1rl}) + b_{53} * (\dot{z}_{2rl} - \dot{z}_{1rl})] * L_{rl}$$

$$I_{sy} \ddot{\phi}_3 = \left[k_{13} * (z_{2fr} - z_{1fr}) + b_{13} * (\dot{z}_{2fr} - \dot{z}_{1fr}) \right] * L_1 \\ + \left[k_{43} * (z_{2fl} - z_{1fl}) + b_{43} * (\dot{z}_{2fl} - \dot{z}_{1fl}) \right] * L_1 \\ - \left[k_{23} * (z_{2rr} - z_{1rr}) + b_{23} * (\dot{z}_{2rr} - \dot{z}_{1rr}) \right] * L_2 \\ - \left[k_{53} * (z_{2rl} - z_{1rl}) + b_{53} * (\dot{z}_{2rl} - \dot{z}_{1rl}) \right] * L_2$$

Maticový zápis

$$\begin{bmatrix} m_1 & 0 & 0 & 0 & 0 & 0 & 0 \\ 0 & m_2 & 0 & 0 & 0 & 0 & 0 \\ 0 & 0 & m_3 & 0 & 0 & 0 & 0 \\ 0 & 0 & 0 & m_4 & 0 & 0 & 0 \\ 0 & 0 & 0 & 0 & m_5 & 0 & 0 \\ 0 & 0 & 0 & 0 & 0 & I_{sx} & 0 \\ 0 & 0 & 0 & 0 & 0 & 0 & I_{sy} \end{bmatrix}$$

$$\begin{bmatrix} k_{12} + k_1 & 0 & -k_{12} & 0 & 0 & -k_{12} * l_{fr} & k_{12} * l_1 \\ 0 & k_{22} + k_2 & -k_{22} & 0 & 0 & -k_{22} * l_{rr} & -k_{22} * l_2 \\ -k_{12} & k_{22} & k_{12} + k_{22} + k_{42} + k_{52} & -k_{42} & -k_{52} & k_{12} * l_{fr} + k_{22} * l_{rr} - k_{42} * l_{fl} - k_{52} * l_{rl} & -k_{12} * l_1 + k_{22} * l_2 - k_{42} * l_1 + k_{52} * l_2 \\ 0 & 0 & -k_{42} & k_{42} + k_4 & 0 & k_{42} * l_{fl} & k_{42} * l_1 \\ 0 & 0 & -k_{52} & 0 & k_{52} + k_5 & k_{52} * l_{rl} & -k_{52} * l_2 \\ -k_{12} * l_{fr} & -k_{22} * l_{rr} & k_{12} * l_{fr} + k_{22} * l_{rr} - k_{42} * l_{fl} - k_{52} * l_{rl} & k_{42} * l_{fl} & k_{52} * l_{rl} & k_{12} * l_{fr}^2 + k_{22} * l_{rr}^2 + k_{42} * l_{fl}^2 + k_{52} * l_{rl}^2 & -k_{12} * l_1 * l_{fr} + k_{22} * l_2 * l_{rr} + k_{42} * l_1 * l_{fl} - k_{52} * l_2 * l_{rl} \\ k_{12} * l_1 & -k_{22} * l_2 & -k_{12} * l_1 + k_{22} * l_2 - k_{42} * l_1 + k_{52} * l_2 & k_{42} * l_1 & -k_{52} * l_2 & -k_{12} * l_1 * l_{fr} + k_{22} * l_2 * l_{rr} + k_{42} * l_1 * l_{fl} - k_{52} * l_2 * l_{rl} & k_{12} * l_1^2 + k_{22} * l_2^2 + k_{42} * l_1^2 + k_{52} * l_2^2 \end{bmatrix}$$

$$\begin{bmatrix} b_p & 0 & -b_p & 0 & 0 & -b_p * l_{fr} & b_p * l_1 \\ 0 & b_z & -b_z & 0 & 0 & -b_z * l_{rr} & -b_z * l_2 \\ -b_p & b_z & b_p + b_p + b_z + b_z & -b_p & -b_z & b_p * l_{fr} + b_z * l_{rr} - b_p * l_{fl} - b_z * l_{rl} & -b_p * l_1 + b_z * l_2 - b_p * l_1 + b_z * l_2 \\ 0 & 0 & -b_p & b & 0 & b_p * l_{fl} & b_p * l_1 \\ 0 & 0 & -b_z & 0 & b_z & b_z * l_{rl} & -b_z * l_2 \\ -b_p * l_{fr} & -b_z * l_{rr} & b_p * (l_{fr} - l_{fl}) + b_z * (l_{rr} - l_{rl}) & b_p * l_{fl} & b_z * l_{rl} & b_p * l_{fr}^2 + b_z * l_{rr}^2 + b_p * l_{fl}^2 + b_z * l_{rl}^2 & b_p * l_1 * (-l_{fr} + l_{fl}) + b_z * l_2 * (l_{rr} - l_{rl}) \\ b_p * l_1 & -b_z * l_2 & -b_p * l_1 + b_z * l_2 - b_p * l_1 + b_z * l_2 & b_p * l_1 & -b_z * l_2 & -b_p * l_1 * l_{fr} + b_z * l_2 * l_{rr} + b_p * l_1 * l_{fl} - b_z * l_2 * l_{rl} & 2 * b_p * l_1^2 + 2 * b_z * l_2^2 \end{bmatrix}$$

Model v Simulinku

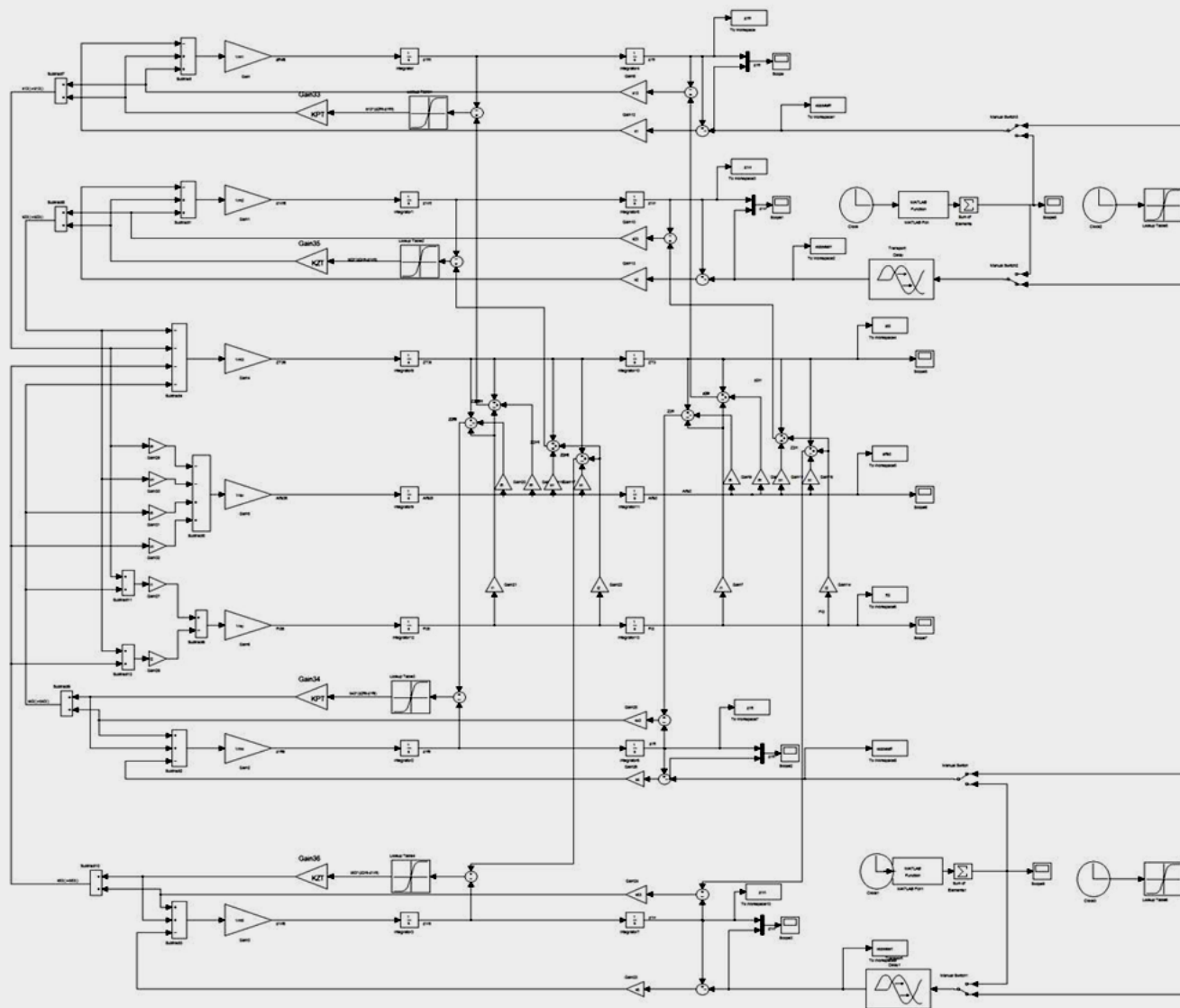

Model v SimPacku

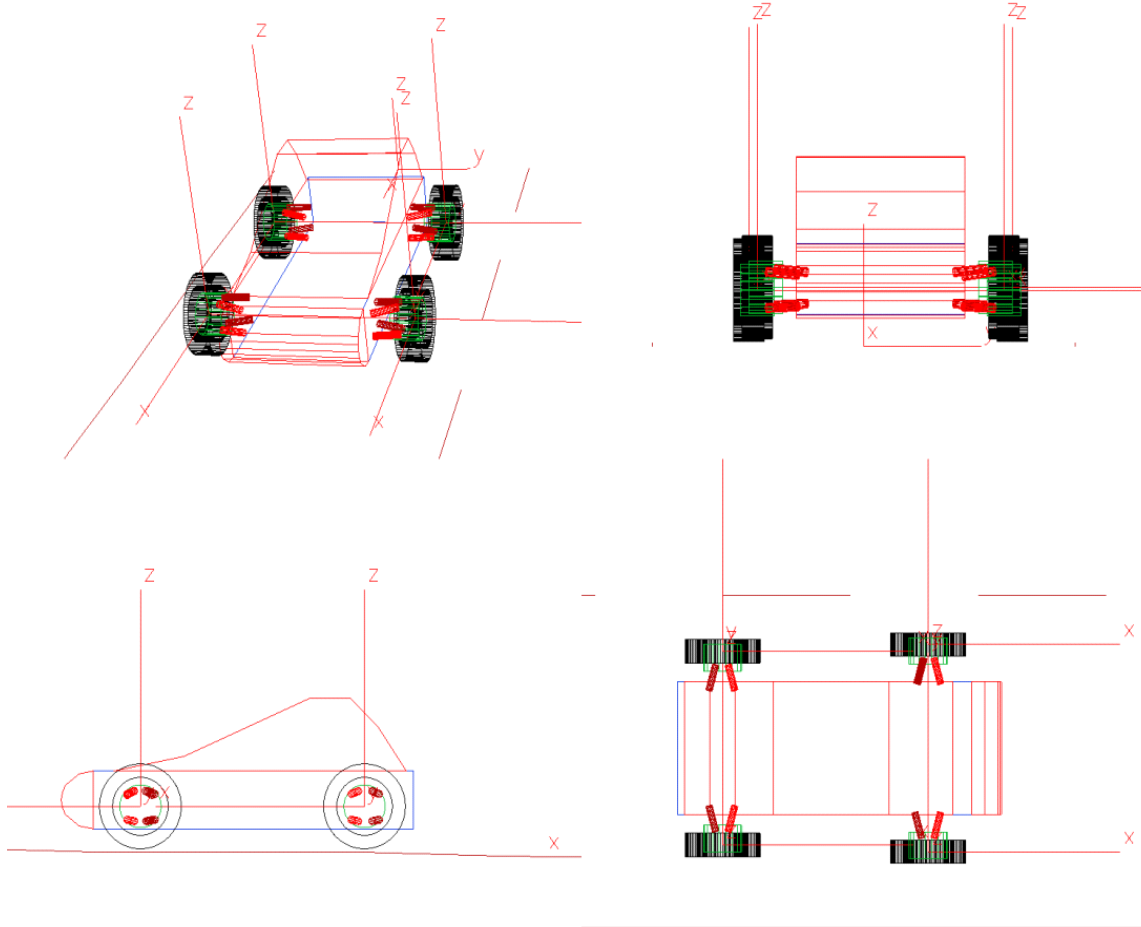

Porovnání modelů

